

Ports and Connectors

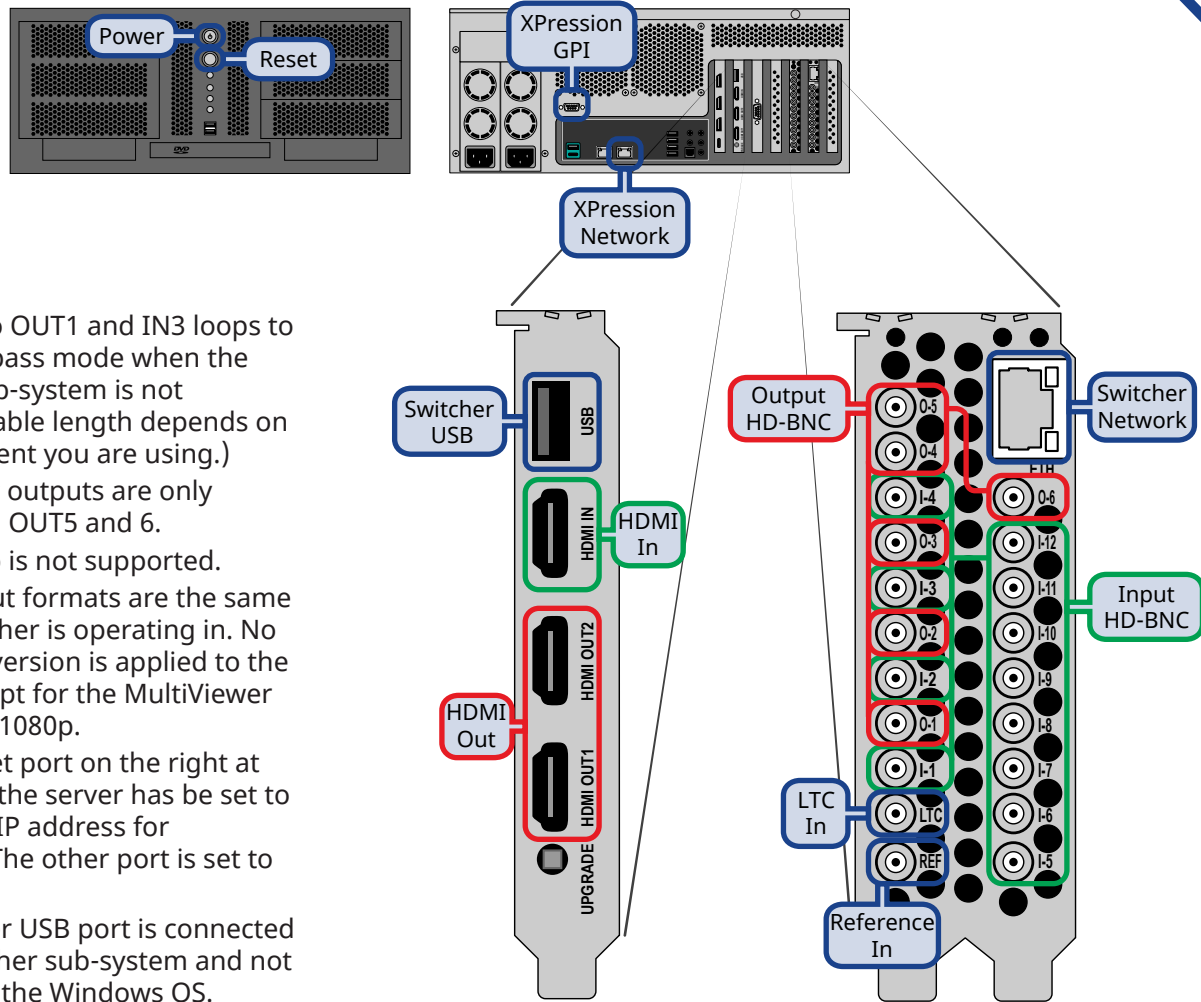

Notes:

- IN1 loops to OUT1 and IN3 loops to OUT3 in bypass mode when the switcher sub-system is not running. (Cable length depends on the equipment you are using.)
- MultiViewer outputs are only available on OUT5 and 6.
- HDMI audio is not supported.
- HDMI output formats are the same as the switcher is operating in. No format conversion is applied to the output except for the MultiViewer that can be 1080p.
- The ethernet port on the right at the back of the server has to be set to the default IP address for XPression. The other port is set to DHCP.
- The Switcher USB port is connected to the switcher sub-system and not available to the Windows OS.

Power and Control Cabling

Note: If you direct connect XPression to Carbonite, you must run DashBoard on the XPression server and you cannot connect a separate control panel to Carbonite.

CAUTION: Wear an ESD grounding strap connected to the chassis thumb screw (Ground Point) before servicing the rear of the unit when power is on.

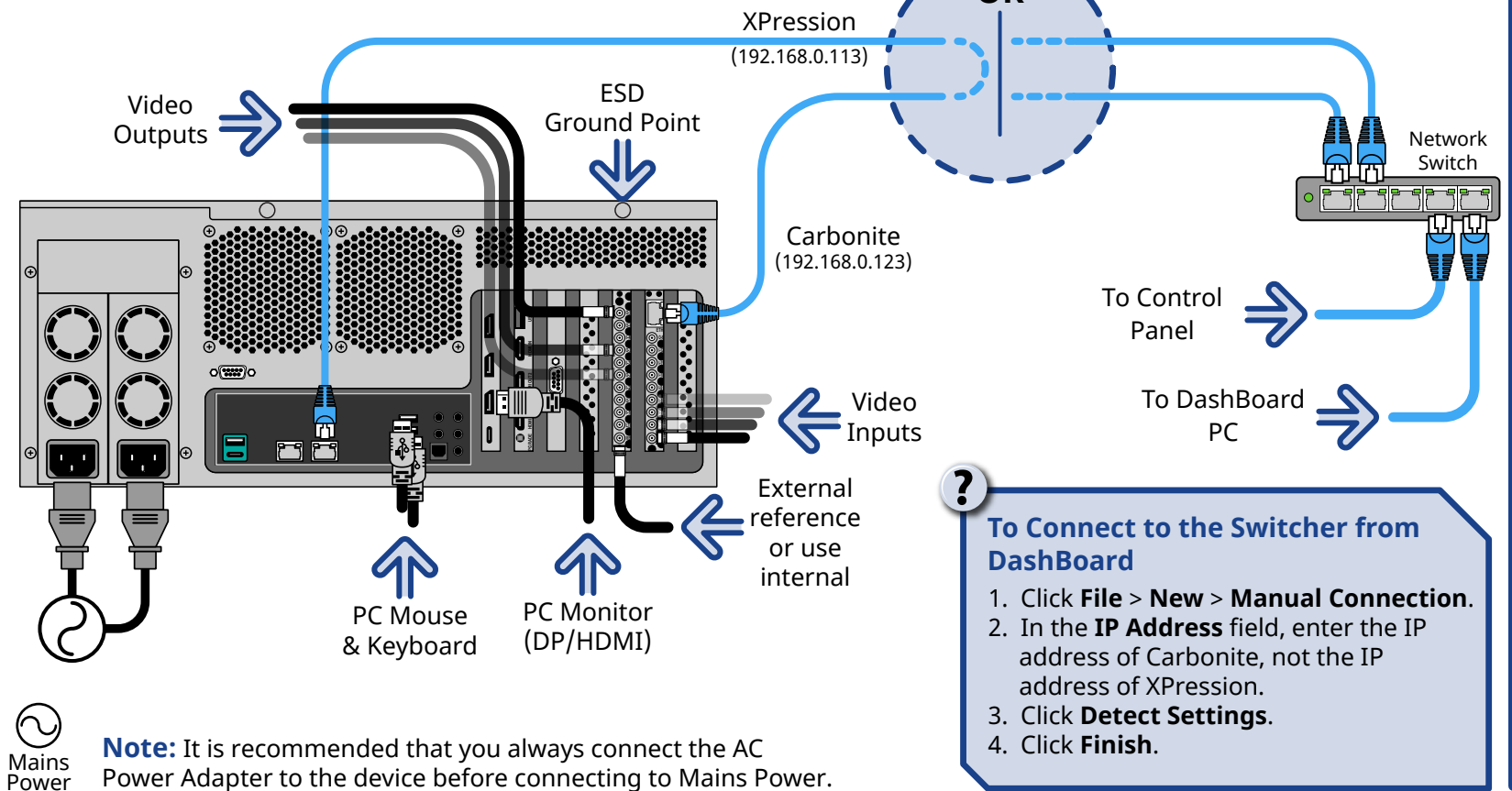

Note: It is recommended that you always connect the AC Power Adapter to the device before connecting to Mains Power.

Direct Connect XPression and Carbonite Ethernet Ports
OR
Connect to External Network Switch

To Connect to the Switcher from Dashboard

1. Click **File > New > Manual Connection**.
2. In the **IP Address** field, enter the IP address of Carbonite, not the IP address of XPression.
3. Click **Detect Settings**.
4. Click **Finish**.

Specifications

Video Input Formats
480i 59.94Hz
576i 50Hz
720p 59.94Hz
720p 50Hz
1080i 59.94Hz
1080i 50Hz
1080pSF 23.98Hz
1080pSF 25Hz
1080pSF 29.97Hz
1080p 25Hz
1080p 29.97Hz
1080p 50Hz Level A
1080p 59.94Hz Level A

Default Values	
Switcher IP	192.168.0.123
XPression IP	192.168.0.113
FTP User name	user
FTP Password	password
Tally Rating	
Input Voltage:	24VAC (rms) / 40VDC
Maximum Current:	120mA
Impedance:	< 15 ohms
Temperature	
Operating:	0 - 40°C (32 - 104°F)
Storage:	-20 - 85°C (-4 - 185°F)

Power Consumption	
PC	520W 4.7A 120V
Audio Breakout	45W 3.75A 12V
Input Voltages	
All	100 - 120V~
	220 - 240V~
	47-63Hz

Video Input Specifications	
Equalization	>50m @ 3Gb/s
(Belden 1694 cable)	>100m @ 1.5 Gb/s
	>300m @ 270 Mb/s (5°-40°C)
Impedance	75 ohm, terminating
Video Inputs, SDI	SMPTE 259M/292M (non-looping)
Video Inputs, HDMI	HDMI 1.4
	High Speed Cable (Max 10m)
Ref Inputs (75 ohm, terminated)	SD — analog black
	HD — tri-level sync

Video Output Specifications	
Return Loss (w/o bypass)	>15dB 5Mb/s to 1.5Gb/s
	>10dB 1.5Gb/s to 3Gb/s
Return Loss (w/ bypass)	>13dB 5Mb/s to 1.5Gb/s
	>10dB 1.5Gb/s to 3Gb/s
Rise & Fall Time	800ps +/- 10% (SD)
	240ps +/- 10% (HD)
Signal Level	800mV +/- 10%
DC Offset	0 Volts
Overshoot	< 10%
SDI HD Mode	10-bit SMPTE-292M
HDMI	HDMI 1.4
	High Speed Cable

Analog Audio Input Specifications	
Input Impedance	XLR: 2K ohm
	¼" Jack: 10K ohm
Maximum Level	+24dBu
Frequency Response	±0.3dB (22Hz to 20kHz @ Fs = 48kHz)
	20kHz @ Fs = 48kHz)
Signal to Noise Ratio "A" weighting	-95dB
	-98dB
CCITT weighting	-107dB
THD	>93dB or <0.002%
Amplitude Linearity	<0.8dB @ -100dBFS
Crosstalk	-94dB

Analog Audio Output Specifications	
Maximum Level	+24dBu
Frequency Response	±0.4dB (22Hz to 20kHz @ Fs = 48kHz)
Signal to Noise Ratio	-103dB
THD	>93dB
Amplitude Linearity	<0.3dB @ -100dBFS
Crosstalk	-106dB (20Hz to 20kHz)

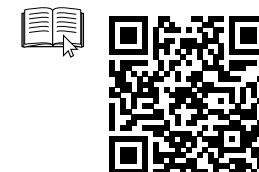

Caution: Before you set up and operate your switcher, see the "Important Safety Instructions" in your User manual.

Rack Mounting

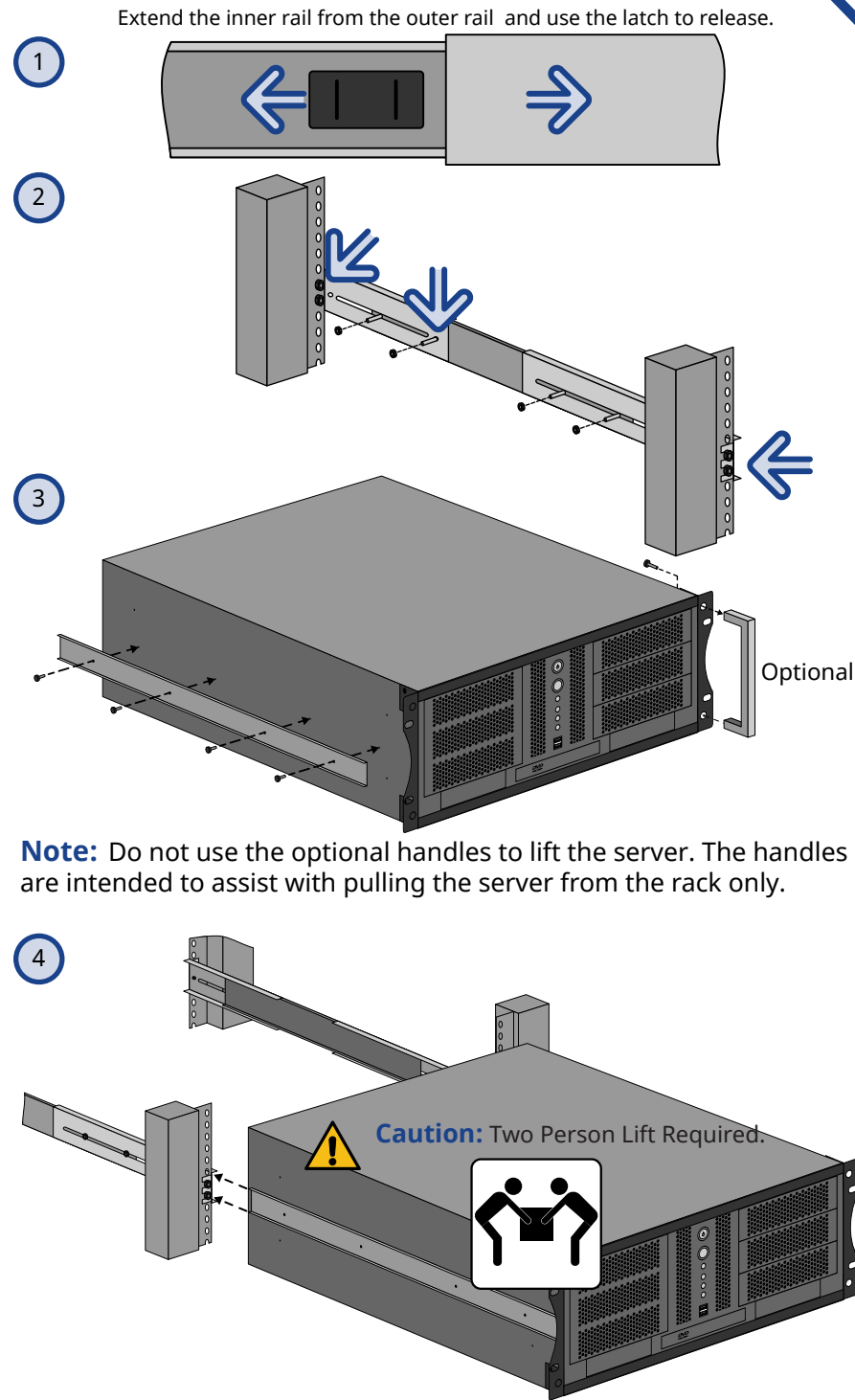

Audio Breakout Module (ABM)

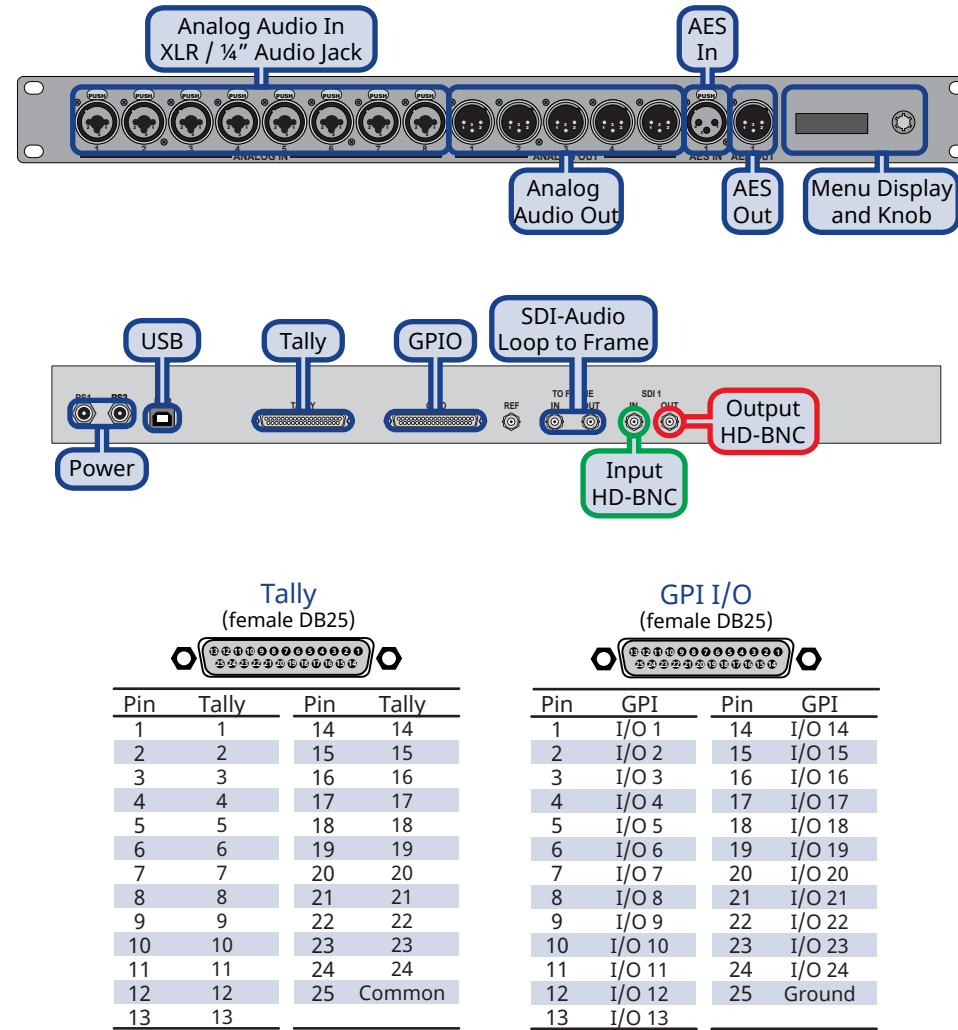

Notes:

- All digital audio must be reference locked (timed) to the same reference that the switcher subsystem is using. This includes both SDI embedded audio and AES audio inputs on the 1RU Audio Breakout Module.
- The SDI-Audio Loop HD-BNCs are for passing embedded audio to and from the audio mixer.
- The SDI1 In and Out HD-BNCs replace the HD-BNCs on the server that are used by the Audio Breakout Unit.
- The REF input is not available at this time.

Power and Cabling

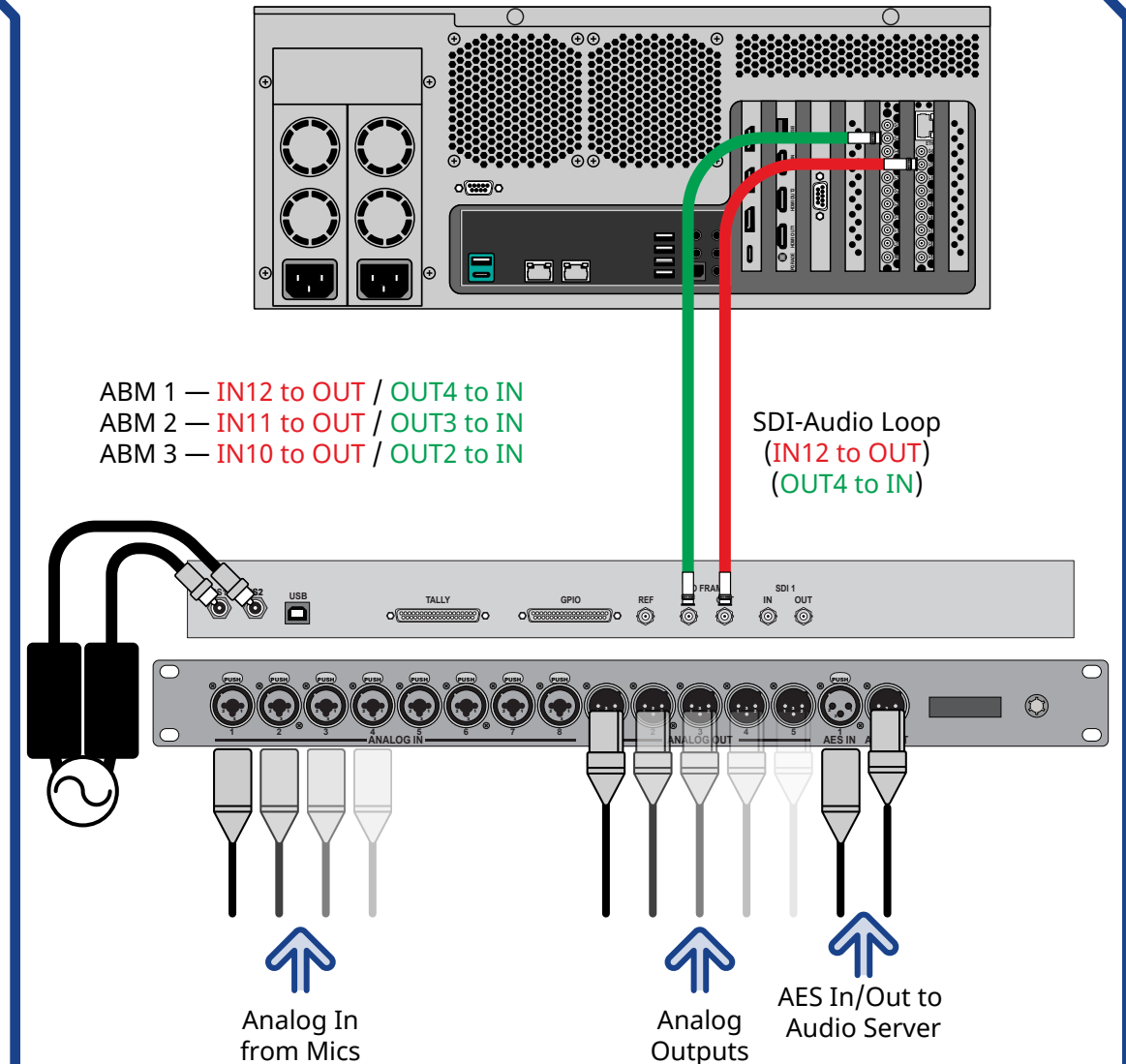

Important: Ensure that Phantom Power is turned off for the Analog Input unless you are connecting a microphone that requires phantom power. Connecting the line out from an audio device to the analog input with phantom power on could damage the audio device and/or the 1RU Audio Breakout Module. For added safety, a TRS phone connector should be used for line in audio sources.



Note: It is recommended that you always connect the AC Power Adapter to the device before connecting to Mains Power.



Having a problem? Call our free, 24-hour technical support hotline to speak with a live product specialist located right here in our facility.

Tel: (+1) 613 • 652 • 4886
 Email: techsupport@rossvideo.com